



TAVLIT TVD ADIR AUTOMATIC DISC FILTER BATTERIES

Tavlit line of automatic disc filters model TVD combines high quality depth filtration with efficient flushing of the disc element.

This unique automatic disc filter (patented), enables flushing at a very low pressure of 150kPa as compared to 300kPa normally required by similar systems.

The innovative technology of the filter uses venturi devices inserted at the spine's inlets that introduce air during the flushing process to enhance it. The mixture of air and water enables more efficient flushing, uses smaller quantities of water for flushing and shortens the flushing time. It also enables proper flushing at a low pressure. The use of air also cushions the discs thereby reducing friction and prolonging the disc element life. The venturi devices inject air from the atmosphere and no external power or compressed air is required. The venturi devices are open only during flushing and do not operate during filtration.

The filter element is composed of grooved discs. The grooved discs are compressed together to form the filtration element. The intersections between the grooves and the outer surface of the element offer a large effective filtration surface within the depth area used to stop debris and is especially effective in filtration of organic matter. Shorter delays between flushing may be required for excessive organic loads.

FILTRATION PROCESS

Water enters the filter and flows through the discs from the outer surface into the inner space.

The dirt accumulates on the outer surface and between the grooves and filtered water flows to the outlet of the filter.

FLUSHING PROCESS

Accumulation of the dirt increases the head loss across the filtration battery.

When the head loss reaches a pre-set value (usually 50kPa; 7psi) the controller performs a flushing cycle, flushing one filter after the other. During flushing air is introduced into the spines. The mixture of air and water enables highly efficient flushing, uses smaller quantities of water and shortens the flushing time. Additionally, the controller has pre-set time based flushing as a backup.

RECOMMENDED BACKWASHING SETTINGS

- DP setting is set at 0.5 bar (50kPa)
- Flush time 30 seconds
- Delay 2 hours

Users should monitor the drop in pressure across the inlet and outlet on the three way pressure gauge at the inlet manifold. The time it takes to reach a 50kPa drop across the filter is the flushing cycle delay - if possible set your delay to minus 30 minutes. Set the flush time to 30 seconds or whichever time it takes to return pressure drop below 20kPa across the filter.



FILTRATION_TAVLIT_TVD-3_V1.05-20

www.hrproducts.com.au



PERTH

PH: 08 9484 6500

FAX: 08 9455 1680

hrsales@hrproducts.com.au

SYDNEY

PH: 02 9616 1300

FAX: 02 9725 5283

infonsw@hrproducts.com.au

MELBOURNE

PH: 03 8458 7400

FAX: 03 9457 7400

infovic@hrproducts.com.au

BRISBANE

PH: 07 3080 6200

FAX: 07 3806 0533

infoqld@hrproducts.com.au

ADELAIDE

PH: 08 8408 7200

FAX: 08 8341 0707

infossa@hrproducts.com.au



TAVLIT TVD ADIR AUTOMATIC DISC FILTER BATTERIES

APPLICATIONS

- As main filter battery for AG, Turf and large landscape projects.
- Suitable for low quality water, especially water with a high load of organic matter.
- Used as pre-filtration in systems when a high degree of filtration is used to protect the main filters.

TECHNICAL INFORMATION

- Available in 50mm and 80mm inlet head size for various flow rates
- Maximum operating pressure: 1,000 kPa
- Minimum pressure required for flushing: 150kPa
- Backflush flow rate: 7.0 m³/h (at 150kPa)
- Filtration grade: 120 micron/mesh

Adir TVD Automatic Disc Filter

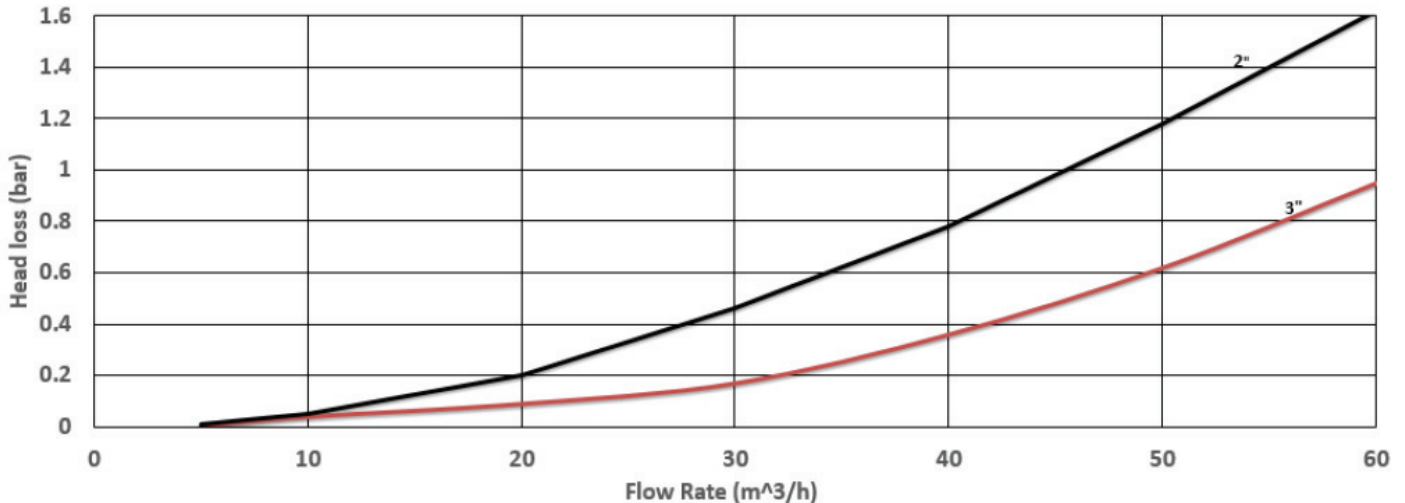

FILTER BATTERY	CONNECTION FLANGED TABLE D	FILTRATION AREA CM ²	FILTRATION VOLUME M ³	WATER QUALITY GOOD (M ³ /HR)	WATER QUALITY AVERAGE (M ³ /HR)	WATER QUALITY POOR (M ³ /HR)	CODE
2 X 2"	3"	2,200	2,870	40	30	20	TVD22130MIC
3 X 2"	4"	3,300	4,290	60	45	30	TVD32130MIC
3 X 3"	6"	3,300	4,290	90	75	60	TVD33130MIC

Other filter microns available on request

FILTRATION_TAVLIT_TVD-3_V1.05-20

www.hrproducts.com.au



PERTH

PH: 08 9484 6500

FAX: 08 9455 1680

hrsales@hrproducts.com.au

SYDNEY

PH: 02 9616 1300

FAX: 02 9725 5283

infonsw@hrproducts.com.au

MELBOURNE

PH: 03 8458 7400

FAX: 03 9457 7400

infovic@hrproducts.com.au

BRISBANE

PH: 07 3080 6200

FAX: 07 3806 0533

infoqld@hrproducts.com.au

ADELAIDE

PH: 08 8408 7200

FAX: 08 8341 0707

infosa@hrproducts.com.au



PRODUCT SPECIFICATION

FILTRATION

TAVLIT TVD ADIR AUTOMATIC DISC FILTER BATTERIES

MODEL	PART NUMBER	FILTER INLET / OUTLET	A	B	C	D	E	W	L	H	H1	H2
2 X 2"	TVD22130MIC	2"	800	1200	80	90	320	1000	750	1100	400	150
3 X 2"	TVD32130MIC	2"	1200	1200	100	110	320	1100	1100	1100	400	150
3 X 3"	TVD33130MIC	3"	1200	1200	150	160	320	1100	1100	1200	450	120

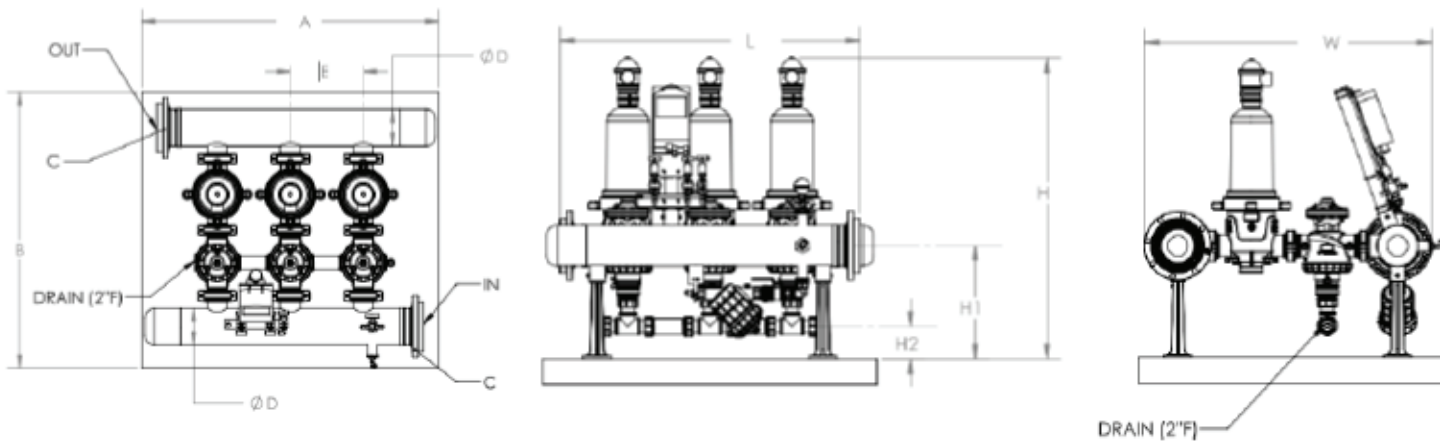

MODEL	PART NUMBER	PIPE SIZE	FLANGE BSTD	HOLES	HOLE DIAMETER MM	CONNECTION TYPE	ENDS
2 X 2"	TVD22130MIC	90	3"	4	16	FLANGED	CAPPED VICTAULIC
3 X 2"	TVD32130MIC	110	4"	4	18	FLANGED	WELDED
3 X 3"	TVD33130MIC	160	6"	8	18	FLANGED	WELDED

FILTRATION_TAVLIT_TVD-3_V1.05-20

www.hrproducts.com.au



PERTH

PH: 08 9484 6500

FAX: 08 9455 1680

hrsales@hrproducts.com.au

SYDNEY

PH: 02 9616 1300

FAX: 02 9725 5283

infonsw@hrproducts.com.au

MELBOURNE

PH: 03 8458 7400

FAX: 03 9457 7400

infovic@hrproducts.com.au

BRISBANE

PH: 07 3080 6200

FAX: 07 3806 0533

infoqld@hrproducts.com.au

ADELAIDE

PH: 08 8408 7200

FAX: 08 8341 0707

infosa@hrproducts.com.au