



PRODUCT SPECIFICATION



Tavlit ADIR TS Series Filter – Single Action Cleaning

TAVLIT offers semi-automatic screen filters, models TS, for easy effective filtration. The plastic filters are designed for long life and service in hard conditions and include a strong INOX 316 screen mesh. During operation water enters the filter and dirt is accumulated on the inner surface of the screen and clean water is supplied to the field. When the filter is dirty as shown by the head-loss indicator, the user performs a flushing cycle by opening the drain valve and rotating the handle – Opening the drain valve creates low pressure in the suction nozzles and dirt is sucked from the screen to the nozzles. The rotation of the handle moves the suction nozzles on the entire screen area and remove all the accumulated dirt off the screen – debris is flushed through the drain port out of the filter. During the flushing cycle water flow to the field is uninterrupted

Features:

- Available sizes: 50mm & 80mm
- Max working pressure: 10 bar
- Maximum flushing pressure: 6 bar
- Min. flushing pressure: 2 bar.
- Max. flow rate:
50mm: 25 m3/h
80mm: 50 m3/h12
- Available in 80 – 120 mesh
- Flushing flow rate:
50mm – 5.4 m3/h @ 200 kpa
80mm – 6.8 m3/h @ 300 kpa
- Filtration area: 950 cm2
- Construction materials: Nylon+GF Polypropylene
- O ring: E.P.D.M.



MODELS	CODE
50mm Semi-Automatic screen filter (80/120 mesh)	SAF2MSXXX
80mm Semi-Automatic screen filter (80/120 mesh)	SAF3MSXXX

Specifications subject to change without notice – Product drawings / images are representative only and are subject to change.

PERTH

PH: 08 9455 1677
FAX: 08 9455 1680
hrsales@hrproducts.com.au

SYDNEY

PH: 02 9725 5733
FAX: 02 725 5283
infonsw@hrproducts.com.au

MELBOURNE

PH: 03 9457 7500
FAX: 03 9457 7400
infovic@hrproducts.com.au

BRISBANE

PH: 07 3806 0522
FAX: 07 3806 0533
infoqld@hrproducts.com.au

ADELAIDE

PH: 08 8341 0008
FAX: 08 8341 0707
infossa@hrproducts.com.au



PRODUCT SPECIFICATION



Head loss Charts

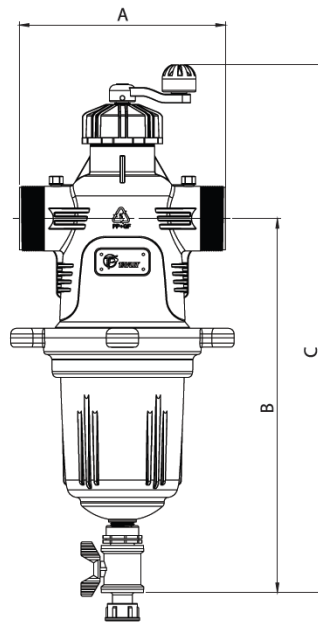
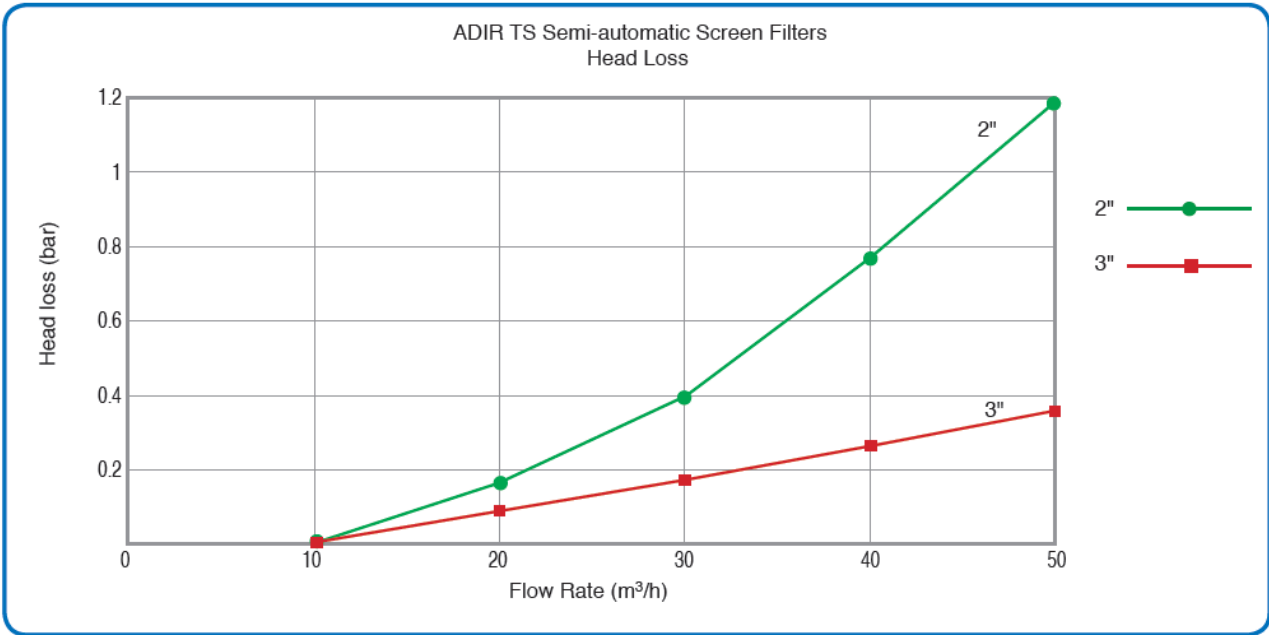

Dimensions

Dimensions (mm)	2"	3"
A	280	280
B	490	508
C	720	750

Specifications subject to change without notice – Product drawings / images are representative only and are subject to change.

PERTH

PH: 08 9455 1677
FAX: 08 9455 1680
hrsales@hrproducts.com.au

SYDNEY

PH: 02 9725 5733
FAX: 02 725 5283
infonsw@hrproducts.com.au

MELBOURNE

PH: 03 9457 7500
FAX: 03 9457 7400
infovic@hrproducts.com.au

BRISBANE

PH: 07 3806 0522
FAX: 07 3806 0533
infoqld@hrproducts.com.au

ADELAIDE

PH: 08 8341 0008
FAX: 08 8341 0707
infosasa@hrproducts.com.au

