



PRODUCT SPECIFICATION

FILTRATION

Tavlit ADIR TS Series Filter – Single Action Cleaning

TAVLIT offers semi-automatic screen filters, models TS, for easy effective filtration. The plastic filters are designed for long life and service in hard conditions and include a strong INOX 316 screen mesh. During operation water enters the filter and dirt is accumulated on the inner surface of the screen and clean water is supplied to the field. When the filter is dirty as shown by the head-loss indicator, the user performs a flushing cycle by opening the drain valve and rotating the handle – Opening the drain valve creates low pressure in the suction nozzles and dirt is sucked from the screen to the nozzles. The rotation of the handle moves the suction nozzles on the entire screen area and remove all the accumulated dirt off the screen – debris is flushed through the drain port out of the filter. During the flushing cycle water flow to the field is uninterrupted.

Applications:

- Water filtration for agriculture, Turf and industry
- Intended as control filter in subsections for easy cleaning.
- Most suitable for low quality water sources where the user prefers to clean the filter without dismantling it.

Features:

- Available sizes: 50mm & 80mm
- Max working pressure: 10 bar
- Min. flushing pressure: 2 bar.
- Max. flow rate:
50mm: 25 m³/h
80mm: 50 m³/h
- Available in 80 – 120 mesh
- Flushing flow rate:
50mm – 5.4 m³/h @ 200 kpa
80mm – 6.8 m³/h @ 300 kpa
- Filtration area: 950 cm²
- Construction materials: Nylon, Polypropylene

Special Features:

- Water flow to the field is uninterrupted.
- Made from high quality plastics materials.
- High quality and robust SS 316 screen.
- Small foot print and large filtration area.
- Tailor made batteries of filters are available for higher flow rates
- Optional—Pressure indicator clearly shows when the filter is dirty and needs flushing



MODELS	CODE
50mm Semi-Automatic screen filter (80/120 mesh)	SAF2MSXXX
80mm Semi-Automatic screen filter (80/120 mesh)	SAF3MSXXX

www.hrproducts.com.au



PERTH

PH: 08 9484 6500

FAX: 08 9455 1680

hrsales@hrproducts.com.au

SYDNEY

PH: 02 9616 1300

FAX: 02 9725 5283

infonsw@hrproducts.com.au

MELBOURNE

PH: 03 8458 7400

FAX: 03 9457 7400

infovic@hrproducts.com.au

BRISBANE

PH: 07 3080 6200

FAX: 07 3806 0533

infoqld@hrproducts.com.au

ADELAIDE

PH: 08 8408 7200

FAX: 08 8341 0707

infosa@hrproducts.com.au

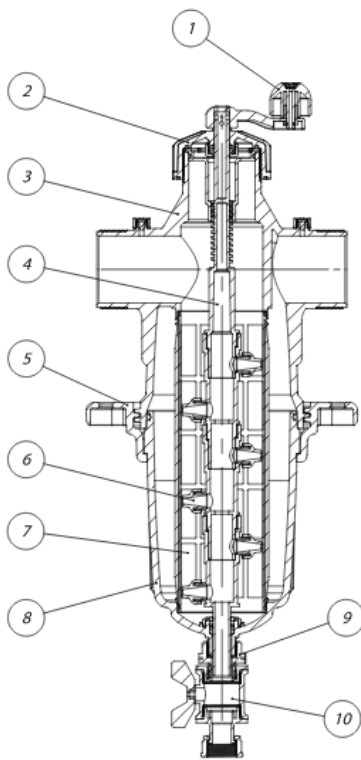

Item No.	Description
1	Handle
2	Cover
3	Filter Body
4	Flush Pipe
5	Locking Ring
5	Nozzle
7	Adir Screen Filter Inox
8	Filter Cup
9	Bushing 1" F / 1" M
10	Flush Valve 1"

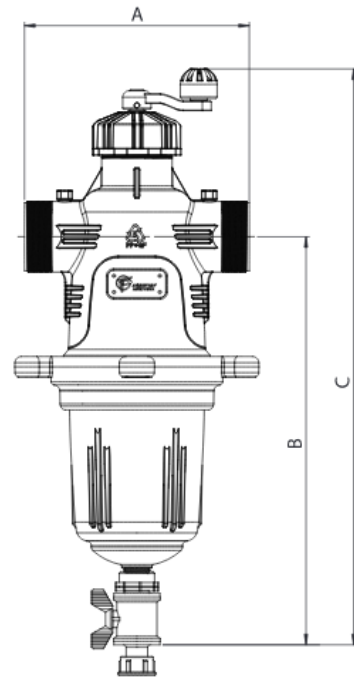

Dimensions

Dimensions (mm)	2"	3"
A	280	280
B	490	508
C	720	750

ADIR TS Semi-automatic Screen Filters
Head Loss

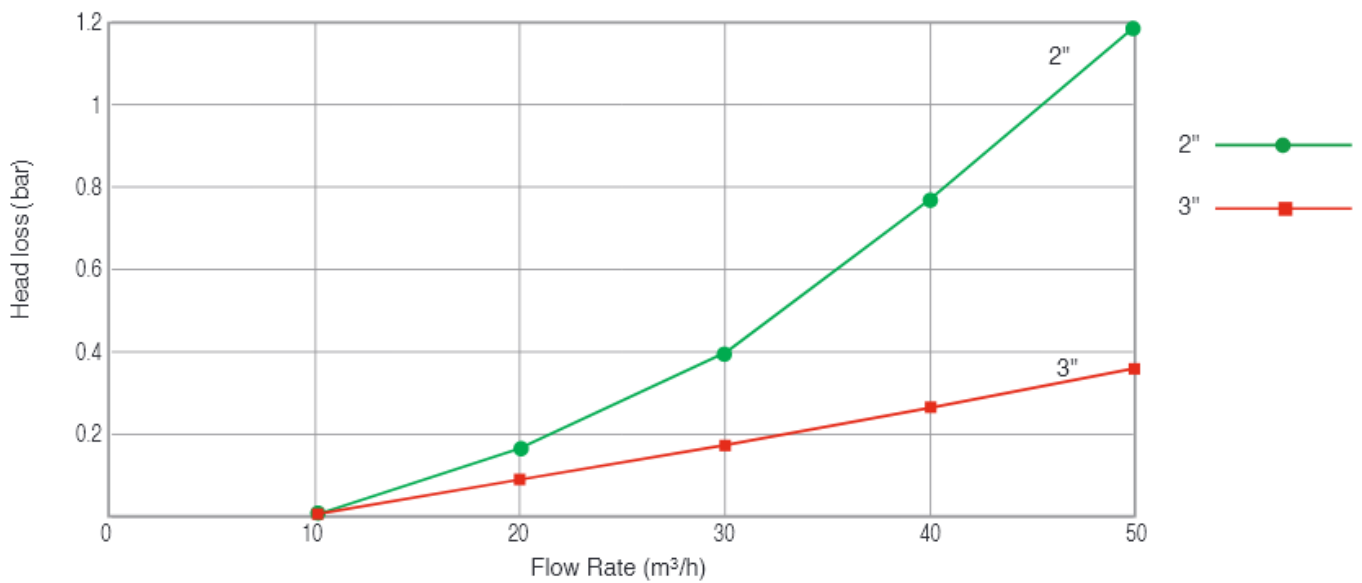

Pressure indicator (optional)

The pressure indicator enables quick and easy way to show the user that the filter is clogged and needs flushing.

When pressure loss across the filter element reaches the preset value, usually 0.5 bar (7 psi), the red button pops up and the user can see from a distance that the filter needs flushing.

There is no need to perform manual pressure tests.

After flushing the button descends into the indicator body.

The device, offered as an-add on, is connected directly to the pressure testing ports located on the filter body.

