



QUICK TIPS

- Ensure that the washers are the correct way around as per installation drawing.
- Use Teflon tape or paste on all threaded connections. Do not over tighten.
- Fully support hoses, piping and valves using structural support independent of tank side wall.

CHEMICAL RESISTANCE

Make sure tank fitting material is compatible with any chemicals which may be used.

Contact Hansen product help line; 0800 HANSEN (0800 426 736) or visit www.hansenproducts.co.nz for information on chemicals resistance or when uncertain conditions exist. As an end user, you must confirm for yourself the applicability of Glass Fibre Reinforced Nylon.

TOOLS

Tools you will need for installing tank fittings properly include:

- Marker pen for marking out holes,
- Tape Measure,
- Straight Edge,
- Drill,
- Hole Saw (sized to the O. D. of the fitting body),
- Deburring Tool,
- Spanners,
- Thread Sealing Tape or Paste.

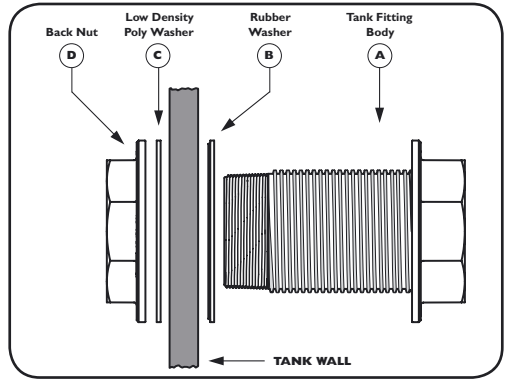

INSTALLATION

1. Check tank manufacturers specific tank fitting installation requirements.
 2. Prior to installing fittings, check the sealing surface for debris and/or scratches which could cause leakage.
 3. Remove the Back Nut (D) and Low Density Poly Washer (C) from the Tank Fitting Body (A)
 4. Slide the Tank Fitting Body (A) through the hole in the tank. The Rubber Washer (B) must be between the fitting body flange and the tank wall (ensure ribs on the Rubber Washer (B) are sealing against tank wall). Fit Low Density Poly Washer (C) and then Back Nut (D) on the tank fitting body thread and tighten.
- To obtain proper washer compression for fitting installation ensure the face of the washers fully contacts the tank wall.
 - Tighten the nut to ensure a water tight seal. Ensure that you comply with the tank manufacturers specifications.
 - All pipe work must be adequately supported.
 - It is recommended that either a thread sealing paste or thread sealing tape be used on all BSPT threaded connections.
 - We recommend Loctite 5331.
 - HANSEN™ Threaded Pipe Fittings can be used in conjunction with metal fittings.

THE HANSEN GUARANTEE: Hansen Products (NZ) Limited UNQUESTIONABLY GUARANTEE to replace any HANSEN™ product which has failed due to a manufacturing fault, and has been installed in the original condition as supplied by Hansen Products (NZ) Limited. We do not accept any liability whatsoever for any consequential damage or for any associated costs involved in repairing or replacing HANSEN™ products. This guarantee does not cover labour, travelling or freight expenses incurring in undertaking a replacement. Any replacement must be made through an authorised HANSEN™ stockist.

HANSEN™ is the internationally registered trademark belonging to HANSEN PRODUCTS (NZ) LIMITED. With our policy of continuing product design and development, specifications, code numbers and items are subject to change without notice. HANSEN PRODUCTS (NZ) LIMITED accepts no responsibility for the misuse or misapplication of this information.